

ASRC_CH_CONF.THROPMODE/RHROPMODE

3

4

ASRC_THRX/RHRX

THR0/
RHR0

DMA Channel 0 for
3, 4, 5 or 6 audio channels (c0, c1, c2, c3, c4, c5)

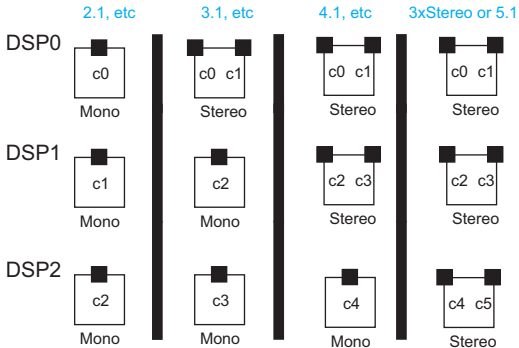

Write THR0 / Read RHR0

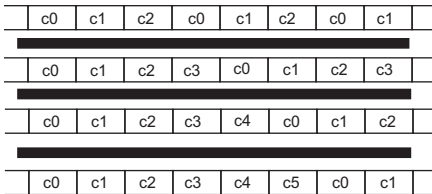

DMA Channel 0 for
4, 5, 6, 7 or 8 audio channels (c0, c1, c2, c3, c4, c5, c6, c7)

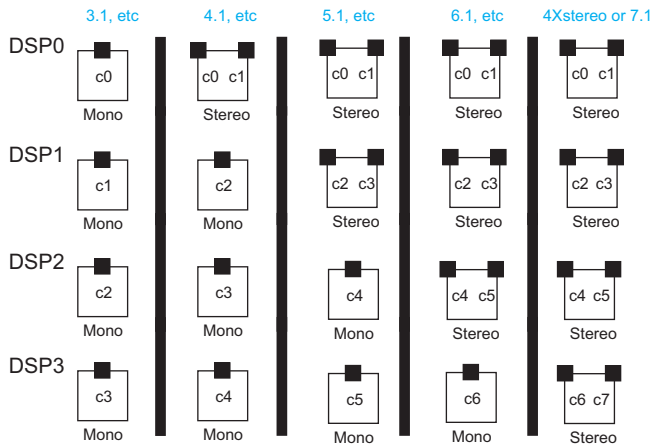

Write THR0 / Read RHR0

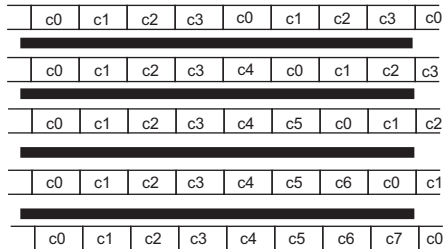

THR1/
RHR1

DMA Channel 1
(1 or 2 audio channels, c0, c1)

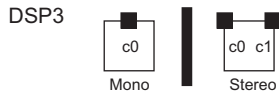

Write THR1 / Read RHR1

