

Write Low Byte

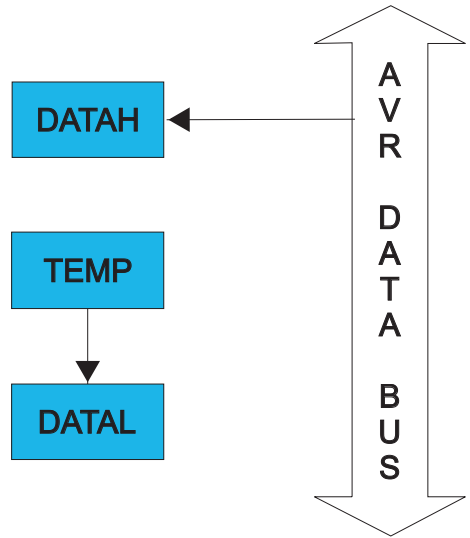

Write High Byte