

# System Controller

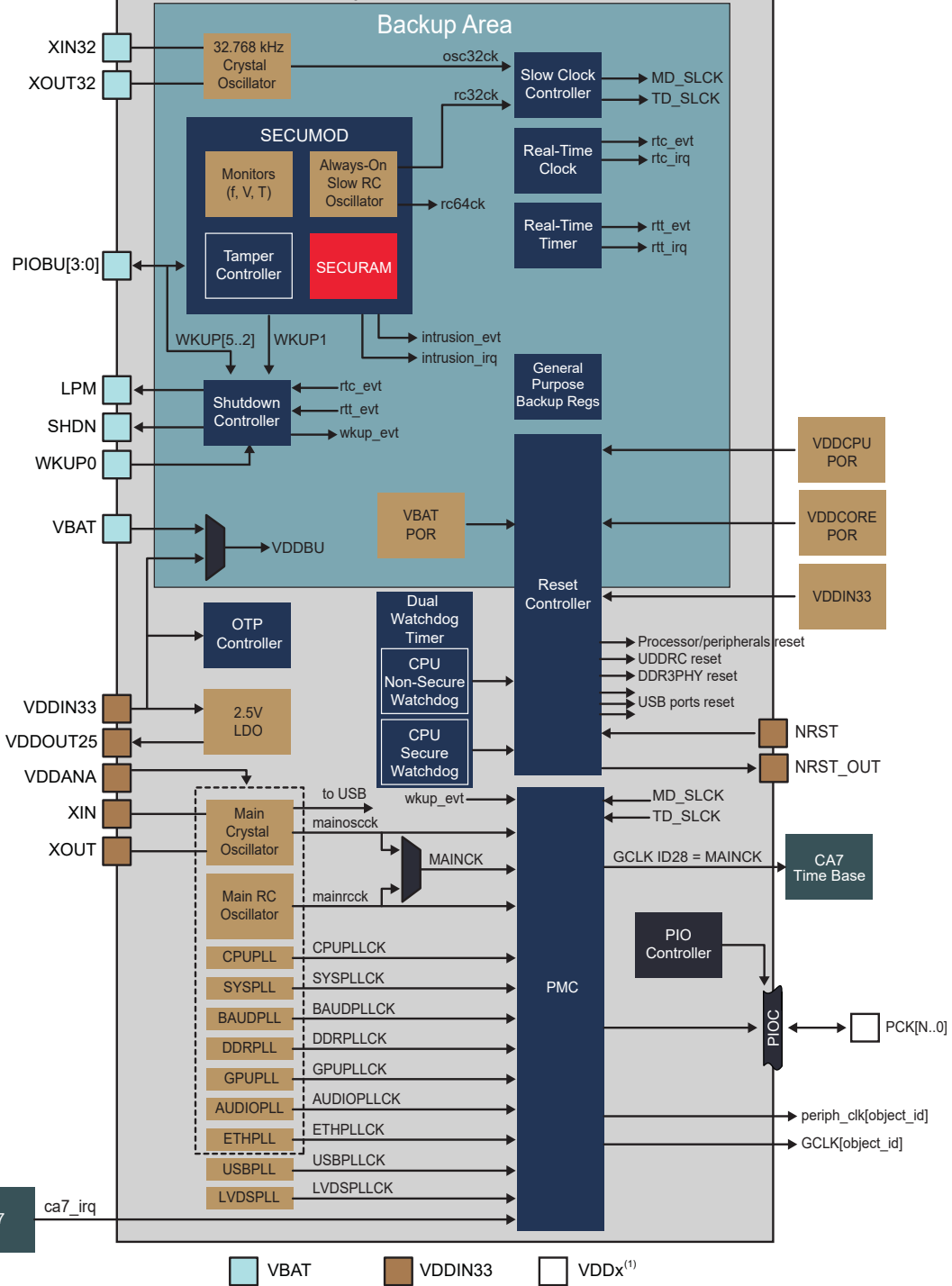

Note<sup>(1)</sup>: refer to the Pin Description table to define the power rail based on I/O multiplexing.