

△ USB: 90Ω ±10% differential trace impedance
 Routing top or bottom

△ MIPI: 100Ω ±10% differential trace impedance
 Routing top or bottom

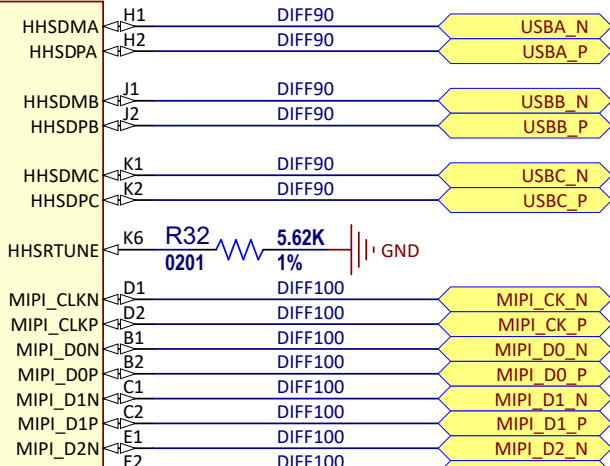

△ USB: 90Ω ±10% differential trace impedance
Routing top or bottom

△ MIPI: 100Ω ±10% differential trace impedance
Routing top or bottom