

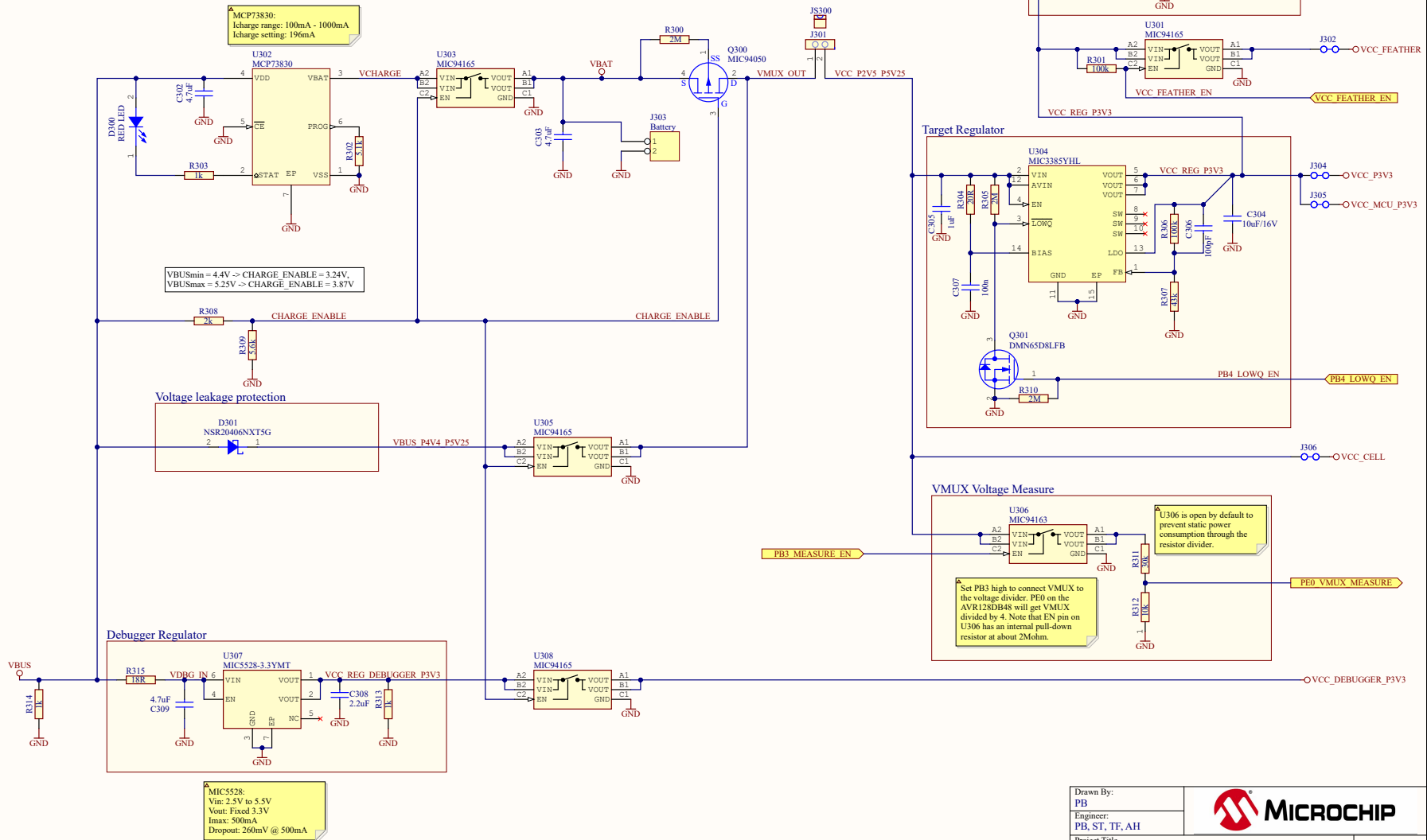

# AVR Cellular Mini Power Supply



Drawn By: PB		
Engineer: PB, ST, TF, AH		
Project Title <b>AVR-IoT Cellular Mini</b>		
Sheet Title <b>Power</b>		
Size A3	PCB Assembly Number: A09-3437	PCBA Revision: 6
	PCB Number: A08-3135	PCB Revision: 2
File: AVR-IoT-Cellular-Mini_Power_SchDoc		Date: 2022-05-04
		Page: 4 of 6