

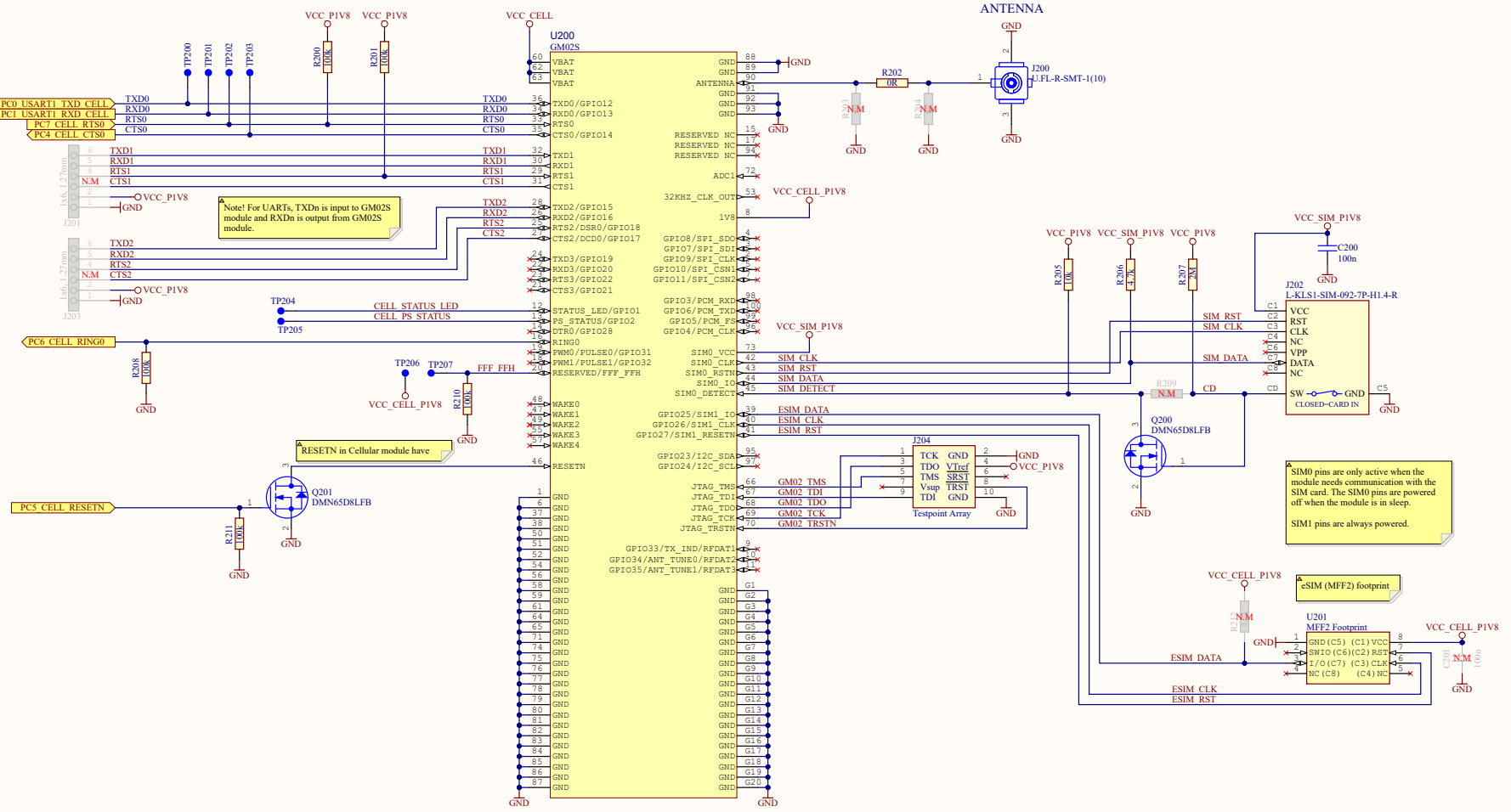

Cellular Module



Drawn By: PB		
Engineer: PB, ST, TF, AH		
Project Title AVR-IoT Cellular Mini		
Sheet Title Cellular Module		
Size A3	PCB Assembly Number: A09-3437	PCBA Revision: 6
	PCB Number: A08-3135	PCB Revision: 2
		Date: 2022-05-04
File: AVR-IoT-Cellular-Mini-Cellular-SchDoc		
Designed with 		Altium.com
Page: 3 of 6		